

Features & Specifications

FRAME MATERIALS:

Main frame – 2x3” 11-gauge oval tubular steel with a combination of 2x2” round tubing.

WELDS:

All welded construction by inert-gas MIG welding conforming with all Structural Welding Code-Steel Standards and Specifications.

FINISH:

Eight-step electrostatically applied powder coat finish.

FRAME COLORS:

Main frame: Platinum Sparkle
Accent: Cathedral Gray

UPHOLSTERY:

Premium grade naugahyde formulated to resist bacteria, stains, mildew and oil. Meets most flammability test requirements. Standard two-tone (Black/Cadet) and double-stitched with “hidden” borders.

Custom colors (one-tone) are available – please inquire with your sales representative.

PADDING:

High density 2” thick rebond urethane foam glued to 1” industrial plywood backing, trimmed and formed to exact fit.

ADJUSTMENT PINS:

1/2” push-pull spring loaded solid steel adjustment pins with ultimate

CABLES:

2200 lbs. test 3/16” military-spec nylon coated cable.

GUIDE RODS:

3/4” solid steel 1045 (tgp) highly polished chrome-plated finish.

BEARINGS:

1” solid steel pivot axles with non-friction 2” sealed bearings (load rating of 2400 lbs.) internally encased on primary pivots, and oil-impregnated bronze bushings on all secondary pivots.

PULLEYS:

4-1/2” and 3-1/2” fiberglass-impregnated nylon pulleys with a precision cable fit V-groove and double sealed roller bearings.

SELECTOR WEIGHT PINS:

Weight pins are solid steel, magnetic with ball-end to ensure a tight connection and secure fit. Coiled lanyard helps prevent pin removal and loss.

FASTENERS:

All frame bolts and nuts are 3/8” and 1/2” zinc plated. Meets ANSI specifications.

WEIGHT STACK:

Black painted solid steel weight plates with self aligning low friction sleeves.

Basic Exercises

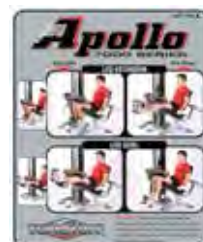

Leg Ext./Curl Station



Leg Press Station



High/Low Station



Multi Press Station



Limited Warranty*

LIFETIME: Frames, welds, cams and weight plates.

5-YEAR: Bushings, pivot bearings, gas-shocks, pulleys, and guide rods.

1-YEAR: Linear bearings and pull-pin components

6-MONTH: Finish, cables, upholstery and rubber grips

ALL OTHER PARTS not mentioned, one year from the date of delivery to the original purchaser.

The warranty set forth herein are conditioned upon proper storage, installation, use and maintenance. All warranty periods begin to run from the date of delivery to the original purchaser. The obligation of TuffStuff under this warranty is limited to repairing or replacing warranted defective parts, as TuffStuff may elect, at TuffStuff's facility in Pomona, California, without charge to the Purchaser for either parts or labor. Purchaser is responsible for installation of repaired or replaced parts, and all transportation and insurance costs to and from TuffStuff's facility in Pomona. *For a detailed copy of the warranty, please contact: TuffStuff 909-629-1600 or info@tuffstuff.net www.tuffstufffitness.com

Corporate



TUFFSTUFF FITNESS EQUIPMENT, INC.

13971 Norton Avenue, Chino, CA 91710

PH: 909-629-1600 FX: 909-629-1600

info@tuffstuff.net

www.tuffstufffitness.com

NOTICE: TuffStuff continually engages in research related to product improvement. As a result, the product received by the customer may differ slightly from its published description. Improvements in materials, production techniques and design refinement may at any time be introduced into our products. TuffStuff reserves the right to make changes in its product without notice.





Includes AP-70CP Center Post

Apollo 7000 Series

For over twenty-six years, the TuffStuff Apollo Series has been the standard against which all other multi-stack gym systems have been measured. The new Apollo 7000 Series offers more than just traditional multi-station gyms. The modular design offers versatility allowing your clients the luxury of customizing a multi-station configuration that best suits their need, or, the added benefit of creating single-station, stand alone modules. With features as legendary as its name and improved versatility, the new Apollo 7000 series is again raising the bar in the multi-stack gym category.

Ideal For . . .

- Hotels, Motels & Resorts
- Condos/Apartment Complexes
- Fire/Police Stations
- Schools and YMCA's
- Rehabilitation Centers
- Armed Services
- Home and Office
- Personal Trainer Studios

Apollo 71LE Leg Extension/Curl

- 6-position adjustable leg hold down accommodates various size users.
- Multi position back pad and biomechanical seat angle provide maximum ergonomic support.
- Custom cam design ensures proper strength curve through entire range of motion.
- Features high-density commercial padding and naugahyde two-tone double-stitched upholstery.
- 200 lbs. steel weight stack.

Requires the purchase of AP-70RP Rear Post.

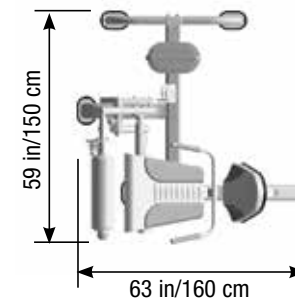

Height: 76 in/193 cm

Exclusive Features:



Lever action control provides easy adjustment in the seated position.



Telescoping back pad adjustment.

NOTE: Shown with optional AP-70RP Rear Post



Apollo Modular Gym Systems

Apollo 71LP Leg Press

- Custom convex footplate provides neutral ankle and knee alignment during exercise.
- Adjustable 6-position ergonomic seat and back pad for easy access and egress from exercise station.
- Heavy weight commercial seat carriage utilizes 2" polyurethane rollers for smooth and precise motion.
- Dual 2" diameter hard chrome seat rails ensure solid reliable performance.
- 200 lbs. steel weight stack with custom 2:1 ratio provides 400 lbs. of weight resistance.

Requires the purchase of AP-70RP Rear Post.

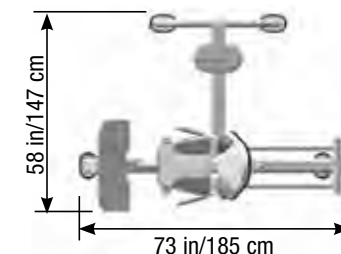

Height: 76 in/193 cm

Exclusive Features:



Commercial seat carriage provides ultra-smooth friction free movement on six 2-inch ball bearing rollers.



Convex press plate provides neutral ankle and knee alignment.

NOTE: Optional AP-70RP Rear Post



Apollo 71MP Multi Press

- Unit can accommodate a variety of exercises from the combined multi press/row station, lat pulldown station, mid pulley and low pulley positions.
- 8-position adjustable press bar.
- Adjustable back pad for custom range of motion settings.
- 360° swivel, multi-directional low pulley station.
- Ratchet-style adjustable seat pad.
- 200 lbs. steel weight stack.

Requires the purchase of AP-70RP Rear Post.

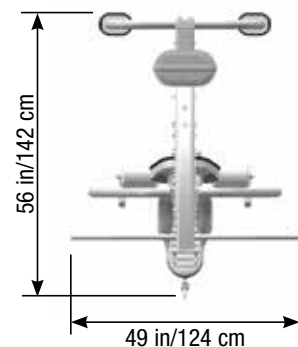

Height: 84 in/213 cm

Exclusive Features:



8-position adjustable press bar provides access to chest, incline, shoulder presses and mid rows.



360° swivel low pulley station features commercial grade 2" roller bearings for smooth unrestricted cable movement.



NOTE:
Shown with optional AP-70RP Rear Post

Apollo Modular Gym Systems

Apollo 71HL High/Low

- Multi-purpose Hi/Low pulley station offers virtually unlimited cable exercise potential.
- Counter-balanced roller style pulley carriage offers single hand adjustability.
- Dual handle pulley carriage allows bilateral and unilateral exercises.
- Custom 1:1/4 cable ratio and ball bearing pulleys provide smooth function and unrestricted cable travel.
- 200 lbs. steel weight stack.

Requires the purchase of AP-70RP Rear Post.

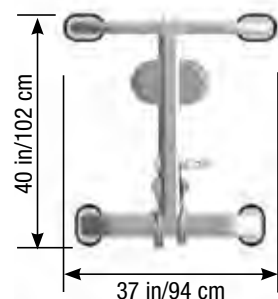

Height: 84 in/213 cm

Exclusive Features:



Quick release counter-balanced pulley carriage offers safe and easy adjustments with dual rotating pulley handles.



Built-in front stabilizer functions as foot brace for low row exercise.



NOTE:
Shown with optional AP-70RP Rear Post

Apollo 7000 SERIES



Includes AP-70CP Center Post

Apollo 7400

- Modular versatility allows customization of station positioning.
- 11-gauge 2"x4" oval and 2" tubular steel frame.
- Durable electro-static powder coat finish in modern Platinum Sparkle and Cathedral Gray.
- Full-length steel weight shrouds and cover plates enhance aesthetics and user safety.
- Integrated exercise placards on weight shrouds provide station description and exercise instruction.
- Elevated frame and integrated rubber stabilizer feet enhance strength and stability.
- Four independent 200 lbs. steel weight stacks allow multiple simultaneous exercise participation.

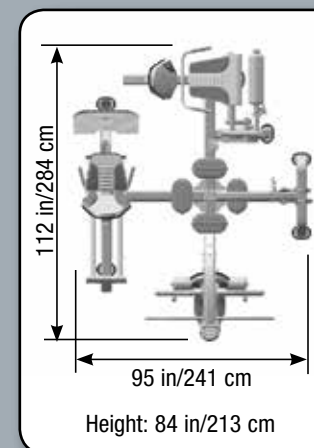

Height: 84 in/213 cm





Includes AP-70CP Center Post



Includes AP-70CP Center Post

Apollo 7300

- Allows for multiple simultaneous users from three independent 200 lbs. steel weight stacks.
- Combination Multi Press/Row station features adjustable seat, back pad and press arm.
- 15-position Hi/Low Pulley station features counter balanced pulley carriage for single hand adjustments.
- Combination Leg Extension/Curl station features ergonomic seat angle, adjustable leg hold down and adjustable back support.
- (3) 200 lbs. steel weight stacks.

Additional configurations and combinations:

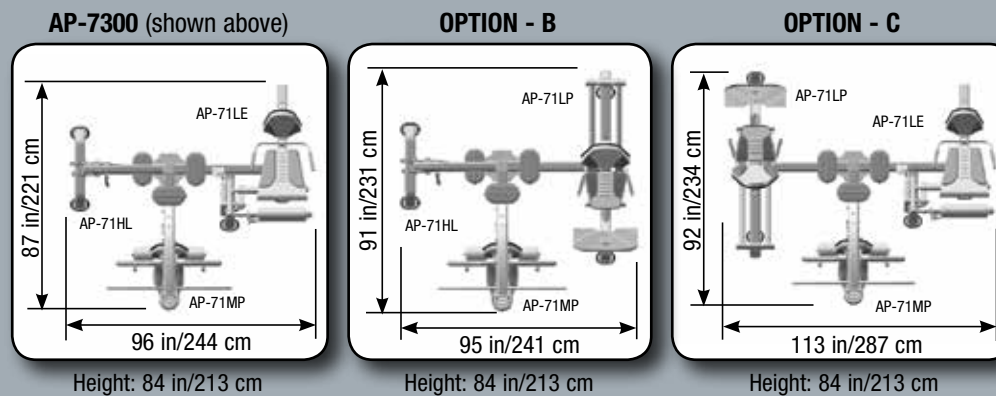

Apollo 7200

- Most compact dual stack gym on the market.
- Modular versatility allows custom station positioning to accommodate various room configurations.
- Full-length steel weight shrouds and cover plates enhance aesthetics and user safety.
- Integrated exercise placards on weight shrouds provide station description and exercise instruction.
- Elevated frame and integrated rubber stabilizer feet enhance strength and stability.
- (2) 200 lbs. steel weight stacks.

Additional configurations and combinations:

